

Measuring Vibration Displacement and Position

Non Contact Eddy-Current Transducers WSG 69/71



Advantages

- Insensitive against oil and other dielectrics in the measurement gap
- Suitable for very high temperature applications
- Adaptor sleeve for wide dimensional range
- Intrinsically safe design
- According to API 670 and DIN 45670

Applications

- Capturing mechanical machine vibrations
- Measuring relative shaft vibration
- Measuring relative shaft position
- Measuring relative and absolute elongation
- Connecting to vibration measuring and monitoring devices

Description

The measuring concept of the eddy-current transducer is based on the physical principle of the damping of a high frequency field through conductive materials. The attenuation ratio is proportional to the distance between the conductive shaft and the transducer coil.

Each transducer requires an adaptor unit containing an oscillator and a demodulator. The option "HT" designates high temperature transducers; the option "Ex" designates explosion proof adaptor units. The separation of the intrinsically safe transducers/ adaptor units and the measuring device is achieved by using safety barriers (Zener barriers). Various accessories are available for different installation options.

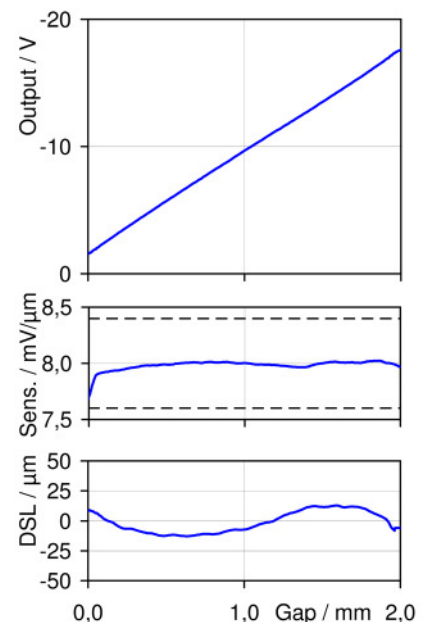

DSL = Deviation from best fit Straight Line at slope 8 mV/μm acc. API 670

Typical static and dynamic characteristic curve of the transducer WSG 69 operating in reference conditions according to DIN 45670

Standard transducers

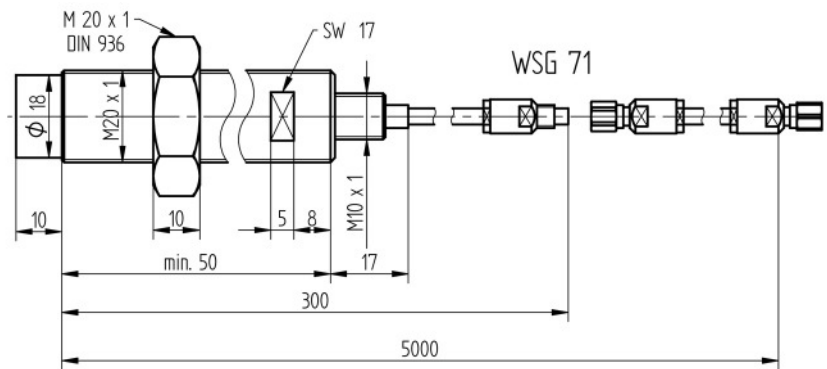
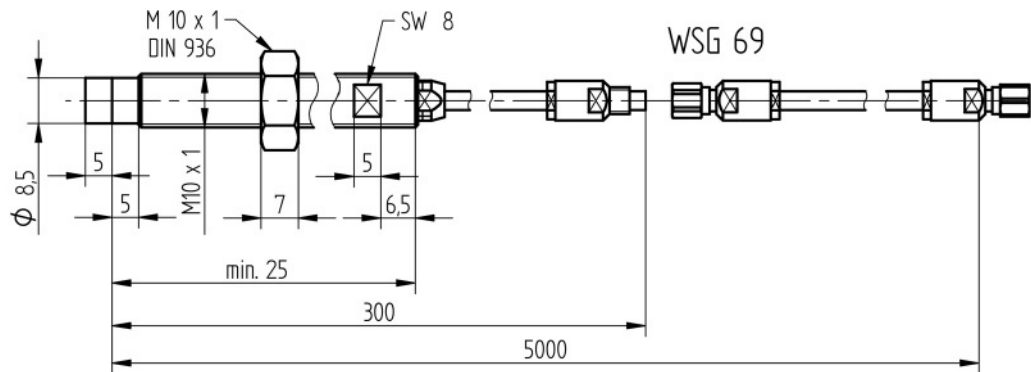

High temperature transducers

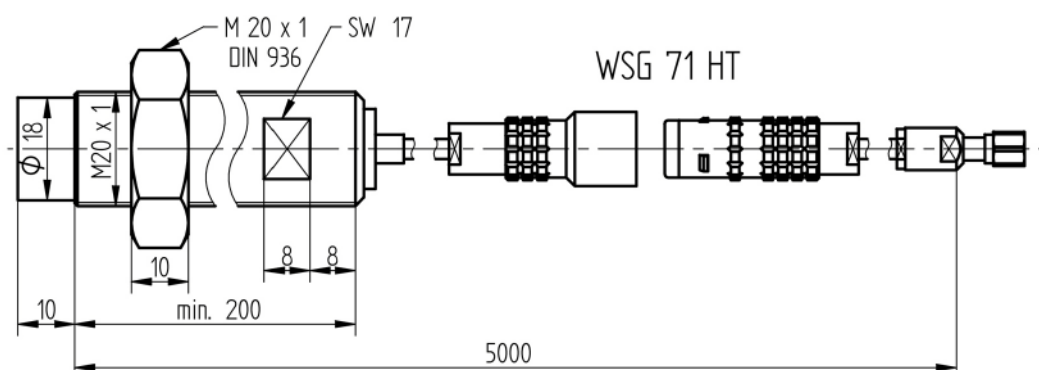
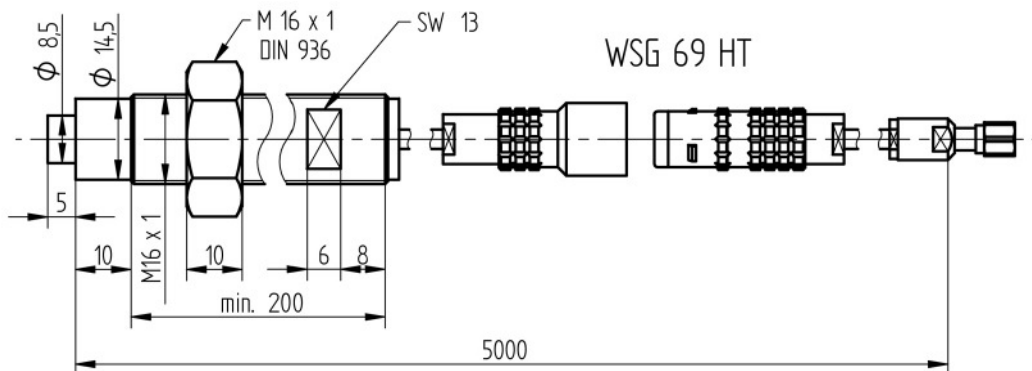



Adaptor unit for WSG 69

Adaptor units 347-00xx

The series 347 - 00xx adaptor units contain the required oscillator and demodulator circuits to operate the WSG series eddy-current transducers.

Adaptor units are installed in appropriate protective housings directly on the machines to be monitored.

Protective housings for two or four adaptor units are available.

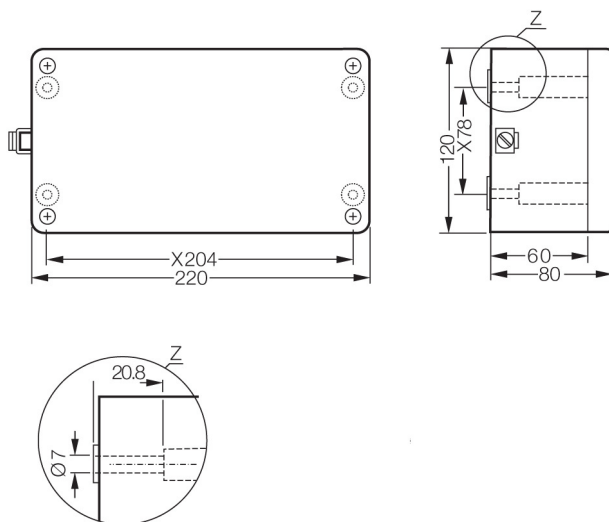

Scope of supply

- Transducer WSG
- Adaptor unit

Options

- Ex version
- Protective hoses
- Protective housing for adaptor unit
- Cable division

Technical data

Transducer	WSG 69	WSG 71
Standard model		
Head diameter	8.5 mm	18 mm
Head material	Ceramic	Ceramic
Connection cable	5 m, divided	5 m, divided
Cable division	at 300 mm	at 300 mm
Cable material	Teflon RG 195	Teflon RG 195
Connector	Brass gold plated / chrome plated	Brass gold plated / chrome plated
Frequency range	0 - 20,000 Hz	0 - 20,000 Hz
Linear range	+/- 1.0 mm	+/- 2.0 mm
Voltage sensitivity	8 mV / μ m	4 mV / μ m
Basic gap	1.5 mm	3 mm
Operating temperature	-10 to +150 °C	-10 to +150 °C
Sleeve length	>25 mm	>50 mm
Sleeve material	Steel # 1.4301	Steel # 1.4301
Carrier sleeve	M 10 x 1 (M 12 x 1; 3/8" UNF)	M 20 x 1
HT version		
Max. operating temperature		
Measuring head	+350 °C	+350 °C
Cable	+200 °C	+200 °C
Adaptor sleeve	M 16 x 1	M 20 x 1
Adaptor unit		
Sensitivity	8 mV / μ m	4 mV / μ m
Supply voltage	-24 V DC	-24 V DC
Operating temperature	-35 to +66 °C	-35 to +66 °C
Storage temperature	-55 to +120 °C	-55 to +120 °C
Humidity	max. 95 %, non-condensing	max. 95 %, non-condensing
Dimensions	40 x 45 x 100 mm	40 x 45 x 100 mm
Weight	appr. 0.2 kg	appr. 0.2 kg

**All information without obligation,
subject to change without notice!**